

PRIMARY USE: To remove hydrocarbon loadings and sediment from parking lot runoff.
ADDITIONAL USES:

MONTGOMERY COUNTY WATER QUALITY INLET

What is it? The Montgomery County water quality inlet is essentially a rectilinear concrete chamber connected to the storm drain system. Runoff passes through three cells modified to separate out grit, oil and sediment before it passes to a storm drain pipe. Also known as: Oil/grit Separator.

Purpose

Oil/grit separators are designed to remove hydrocarbons and sediment from parking lot runoff prior to runoff conveyance to an infiltration BMP or storm drain network. They are particularly appropriate for sites expected to experience a great deal of petroleum residues, e.g., from roads, loading areas, and gas stations, and which have a heavy amount of motor vehicle traffic.

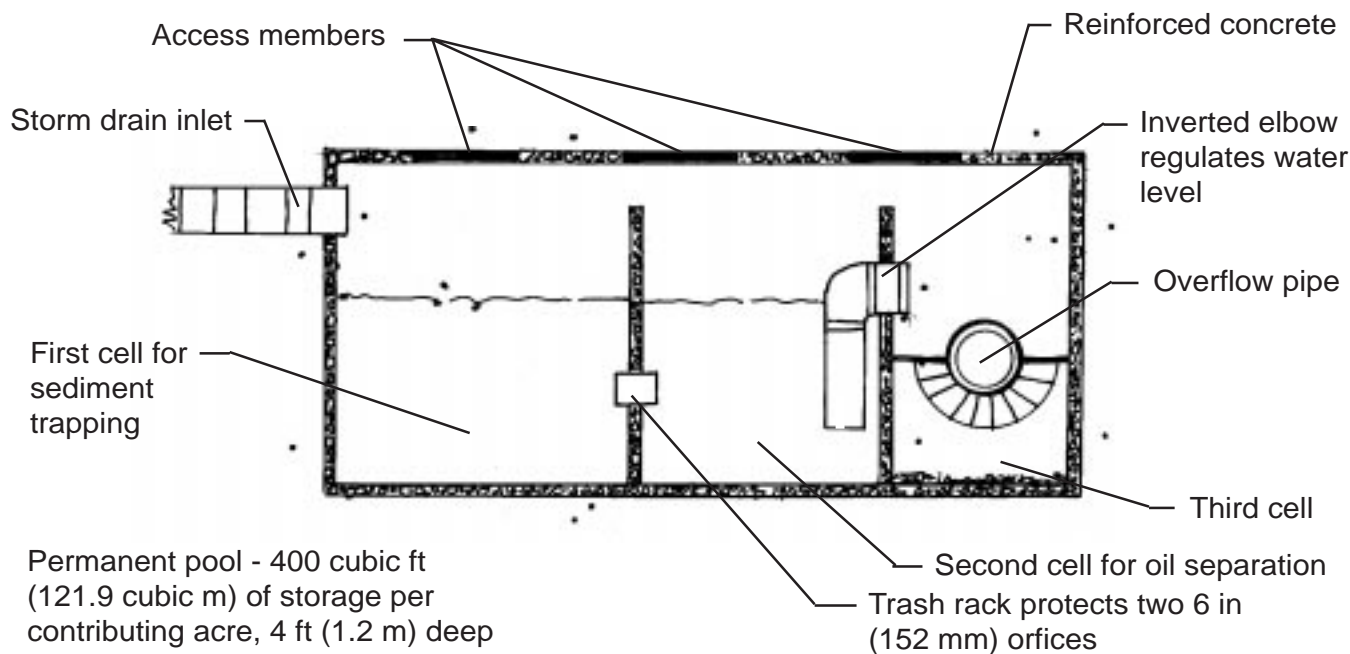

**Oil/Grit Separator
Section View**

Limitations

In general, the limited storage capacities of water quality inlets result in marginal stormwater management benefits. Parking lot sizes are limited to one acre (0.4 hectare). Oil/grit separators store only a fraction of a two year storm design volume. Their limited capacity does not modify the post development peak discharge rate. Only moderate removal of debris, oil and grease, and coarse sediments is likely.

Materials

No special materials required. Refer to accompanying drawing.

Installation

No special guidelines.

Source: Controlling Urban Runoff, Metropolitan Washington.

MONTGOMERY COUNTY WATER QUALITY INLET

Additional Considerations:

The first of the three cells holds a permanent three feet (approximately one meter) deep pool of water, and is linked to the second cell by two well-screened 6 in (152 mm) holes. This chamber settles grit and sediment and catches floating litter. The second cell also holds a permanent pool of water and contains an inverted elbow regulating water level leading to the third cell. Runoff in the second cell passes through the bottom of the elbow and to the third cell. This design is intended to reduce clogging and restrict oil and gas floating on the water surface. The third cell houses a brick cradle which opens to a storm drain outlet pipe. When the cradle is elevated from the cell floor, a third permanent water pool is formed that presents an additional site for settling, and therefore allows for some pollutant removal in this portion of the chamber.

Other reasons for using oil/grit separators relate to their compatibility with storm drain networks, unobtrusiveness, easy access, and ability to treat runoff prior to its entering infiltration BMPs.

Frequent clean-outs are necessary, and disposal of accumulated sediments may be problematic limitations in this project.